



doucette industries, inc.

ECU® DUAL HEAT RECOVERY UNIT

MODEL
HR06
Dual

SPECIFICATION SHEET

HEAT RECOVERY UNIT FOR DOMESTIC HOT WATER FROM RESIDENTIAL HVAC SYSTEMS

DESCRIPTION:

The ECU® Dual Heat Recovery Unit captures waste heat discharged from the refrigerant cycle in two Air Conditioning or Heat Pump systems, and transfers that heat into a water heater tank, thereby creating low cost hot water for domestic use. Not only does the Heat Recovery Unit substantially reduce the amount of energy required to provide domestic hot water, but it also improves the cooling efficiency of each Air Conditioner or Heat Pump while it is operating. The Model HR06 is designed to operate with two systems of 1½ to 5 ton cooling capacity each.

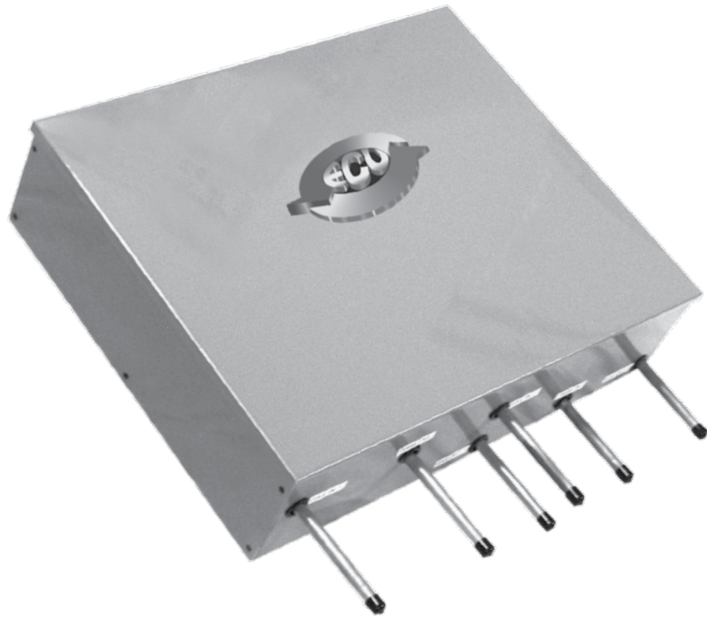

FEATURE HIGHLIGHTS

- 230 volt wiring for easy connection to compressor contactor
- Factory wired and preset controls
- Fully automatic operation
- Two High-Efficiency All-Copper Vented Double-Wall Heat Exchangers
- Water lubricated low wattage Circulator
- Grounded electrical circuit.
- Sturdy Aluminum Cabinet with baked enamel finish for outdoor or indoor use
- ARL listed Appliance, with UL approved components
- Freezestat option available
- Water connection accessories available

APPLICATION:

The refrigerant side of each Heat Recovery Unit Heat Exchanger is installed in the refrigerant hot gas line between the compressor and condenser of each condensing unit; or between compressor and reversing valve, if installed on a Heat Pump System. The water side of the Heat Exchanger is connected to the water heater tank to form a circulation loop. Power is drawn from the compressor contactor. Waste heat may be collected when either compressor operates, and the water circulating from the water heater tank is less than 140°F. A minimum refrigerant temperature of 125°F is required to allow Heat Recovery operation.

APPLICATION CAUTION: Installations subject to freezing ambients must make provision for freeze protection. Heat Recovery Units containing freezestats must draw power from the line side of the compressor contactor. Drainable hand valves are a more positive freeze protection approach.

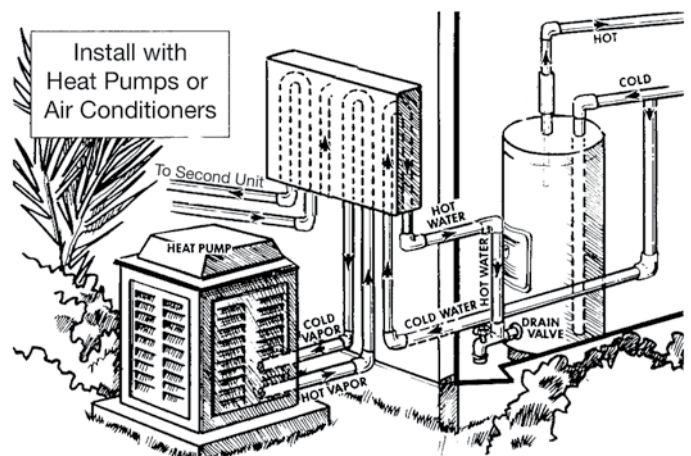

SPECIFICATIONS AND INFORMATION

THESE SPECIFICATIONS SUBJECT TO CHANGE WITHOUT NOTICE.

MOUNTING/LOCATION

ECU® Dual Heat Recovery Units may be mounted indoors or outdoors. They must be mounted vertically, at a height above the top of the condenser. While normally located outdoors near the air conditioning equipment, they can be located in any convenient place, such as the garage or laundry room; but the refrigerant run should be kept to a minimum.

CONTROLS

All ECU® Dual models contain a water high limit control. It is factory set to 140°F. Models also contain two refrigerant gas low limits factory set to 125°F. Freeze-protected models are equipped with a water low limit. It is factory set to 50°F, and is designed to operate when water temperatures of 40°F or less are detected, in order to provide water circulation independent of compressor operation, in the event of freezing ambients.

HEAT EXCHANGER

ECU® Dual Heat Recovery Units contain two corrosion resistant all-copper double wall heat exchanger of counterflow twin tube design. Continuously vented along the entire length, the Heat Exchanger meets strict IAPMO safety criteria, and exceeds UL requirements.

CIRCULATOR PUMP

ECU® Dual Heat Recovery Units contain a low wattage wet rotor in-line single stage circulator. Standard Models use a Taco 008 series, 1/25 hp circulator. This water cooled pump is rated at 113 watts, 230 volts and .49 amps. It is designed for 125 psi working pressure and up to 230°F fluid temperature. The pump housing is bronze and the bearings are ceramic.

TYPICAL WATER INSTALLATION

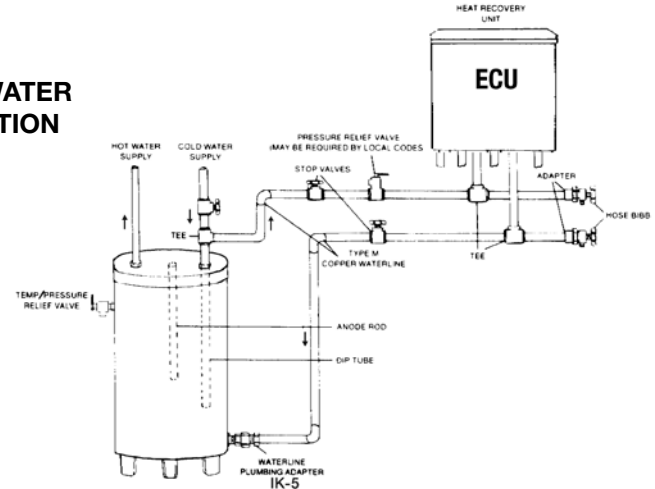
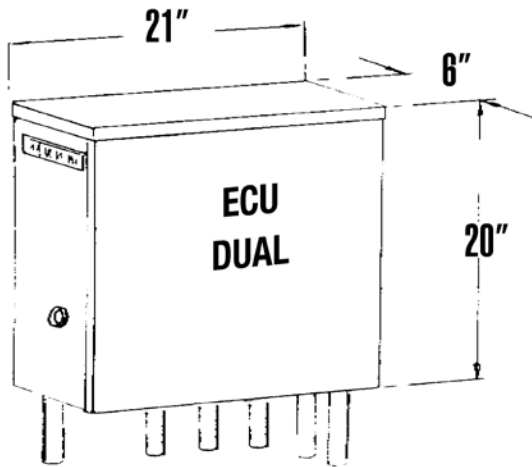

Plumbing hook-up methods can vary, do not "T" returning water into homes hot water supply

WATER LINE SIZING (3/4" Water Stubs)

Actual Size O. D.	Nominal Size	NOMINAL COOLING CAPACITY (BTU/H) EACH A/C SYSTEM			
		24,000	36,000	48,000	60,000
Maximum One-Way Water Line Length (Feet)					
5/8	1/2	150	80	40	24
3/4	5/8	-	150	100	50
7/8	3/4	-	-	150	150

REFRIGERANT LINE SIZING (1/2" O.D. Stubs)

Refrigerant Tube Size O. D.	R-22 Charge Addition per 10 Feet oz.	NOMINAL COOLING CAPACITY (BTU/H) EACH A/C SYSTEM			
		24,000	36,000	48,000	60,000
Maximum One-Way Refrigerant Tube Length (Feet)					
1/2	1.0	16	9	5	-
5/8	2.0	30	25	13	9
3/4	3.0	-	30	30	25

THERMAL PERFORMANCE (ARI 470-2001) EACH A/C SYSTEM

Water Side	Refrigerant Side	Nominal 5 ton Cooling Capacity
EWT: 95°F LWT: 106°F Flow Rate 2.0 gpm	Entering: 178°F Leaving: 114°F Flow Rate 730 lb/hr	Heat Transferred: 11,145 Btuh Testing Performed by Applied Research Labs Miami, FL : Sept. 2007

ACCESSORIES

PART NO.	DESCRIPTION
IK-5	Installation Kit
L140	High water thermostat
L50	Freeze control thermostat
F125	Refrigerant low limit thermostat
PV05D	3/4" pressure relief valve
T008	Taco 008 pump

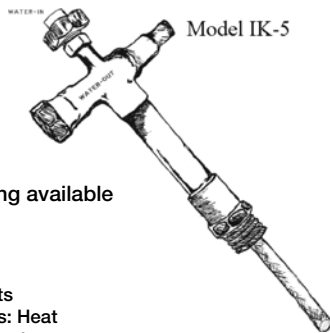

Optional IK-5 easy installation fitting available

WARRANTY: ECU® Heat Recovery Units offer a limited Parts Warranty as follows: Heat Exchanger- 5 Years; Pump- 3 Years; All other components- 1Year.

ECU® Heat Recovery Units

MODEL	FEATURE	SHIP WEIGHT
HR06 Dual	Base Model	32 lbs
HR06-F Dual	with Freeze-Stat	
HR06-V Dual	with hand valves & bleed port	
HR06-PC Dual	with hand valves & PRV	
HR06-410a Dual	650 psig unit for R-410a	

High Pressure (650psi test) Models available in all configurations add-410 to model number. All Models suitable for use in 1 1/2 to 5 ton systems. All Models wired 230V 1phase.