

## Item # CC 800 T, Coaxial Heat Exchangers (1 to 15 tons)

1/3 to 15 tons Fresh Water Evaporators

Doucette Coaxial Coils are designed for use as Water Cooled Condensers, Water Chillers and in Water Source Heat Pumps. This design is being used by major OEM's around the world and in the ever expanding wholesale replacement market. Simplicity of design and installation makes this product ideal in both markets.



### Specifications

TR	8
Material	Stainless Steel
Refrig. In	7/8 "
Refrig. Out	1 3/8 "
Water Conn.	1 1/4 MPT
Width	14-3/4 "
Length	19 "
Height	22-7/16 "
Weight	124 lbs
Installation Recommendation	System controls should include a calibrated low pressure cutout or an Evaporator Pressure Regulator properly set to prevent freeze-up. For maximum performance fluids should be piped in parallel flow. An externally equalized thermal expansion valve is recommended to compensate for the refrigerant pressure drop through the heat exchanger.

### 3 Reasons to Use Doucette Coaxial Coils

#### • Design

Doucette Coaxial Coils are engineered for maximum heat transfer with the incorporation of the most advanced and innovative tubing in the industry. The copper or cupronickel tubing is deeply fluted to enhance heat transfer and minimize fouling and scaling. Because of this efficient tube design, Doucette units may be used as both a condenser and/or evaporator; making them ideal for heat pump applications.



20 Leigh Drive,  
York, Pennsylvania 17406-8474



Website: [www.doucetteindustries.com](http://www.doucetteindustries.com)



Phone: 717-845-8746  
Toll-free: 800-445-7511  
Fax: 717-845-2864



Commercial/Industrial: [AdamM@doucetteindustries.com](mailto:AdamM@doucetteindustries.com)  
Residential/Light Commercial: [AdamM@doucetteindustries.com](mailto:AdamM@doucetteindustries.com)

OEM's periodically change product design and, as a result, after market technicians sometime suffer because of it. Doucette has incorporated a universal mounting bracket for ease of installation to help eliminate those in-field problems.

- **Quality**

Doucette's quality is second to none. Raw materials must meet stringent specification requirements before they are accepted for manufacture. Quality is manually checked at every step of fabrication. Each unit is tested on the water side to 350 psig and on the refrigerant side to 600 psig. All Doucette Coaxial Coils are UL and CSA listed. Quality is the number one obligation to our customers.

- **Delivery**

Doucette maintains a vast inventory of product at our design and manufacturing facilities in York, Pennsylvania, and around the country. Because of this commitment, shipping is generally the same or next day after we receive the order. This is equally valuable to both the Wholesaler and OEM.

---

## Applications and Capabilities

Doucette Coils are designed for R-410A, R-22, R-12, and R-502 and other freon refrigerants. The units are rated at standard ARI conditions, Standard 450-79 using R-22.

- **Condenser Applications** are rated for various TD's (Temperature Difference), Condensing Temperature (CTp) minus Entering Water Temperature (EWT). Nominal Rating at 3 gpm per 15,000 BTUH ton, based on a 23° FTD, 108° F condensing, 85° F EWT.

- **Water-Source Heat Pumps** are rated for various Entering Water Temperature (EWT), typically 70° F EWT, with corresponding Suction Temperatures (ETp). Nominal Rating at 2.4 gpm per 12,000 BTUH ton.

- **Water Chiller Applications**, typical EWT is 54° F at 2.4 gpm per 12,000 BTUH ton. Actual tons will be less than "Nominal Tons" due to the lower EWT. Therefore, select the appropriate coil based on total BTUH cooling requirement. For glycol chilling and other applications, please contact the factory.

---

## Engineering Support

Doucette provides excellent Engineering support. For design or product selection assistance, please call us.

---

## Coaxial Selections

- **Fresh Water Condensers & Evaporators**

The CX Series is designed for fresh water applications using copper water tube and carbon steel outer shell.

- **Marine Condensers & Evaporators**

Doucette manufactures a full line of marine condenser/evaporators, the CXN Series, which are designed for sea water and brackish water applications, using cupronickel water tubes and carbon steel outer shell.

- **Selection and Ordering**

The Quick Selection Table shows each unit rated for BTUH Heat of Rejection (Condenser mode) or Heat of Absorption (Evaporator mode).

We invite your call for product selection assistance.



20 Leigh Drive,  
York, Pennsylvania 17406-8474



Website: [www.doucetteindustries.com](http://www.doucetteindustries.com)



Phone: 717-845-8746  
Toll-free: 800-445-7511  
Fax: 717-845-2864



Commercial/Industrial: [AdamM@doucetteindustries.com](mailto:AdamM@doucetteindustries.com)  
Residential/Light Commercial: [AdamM@doucetteindustries.com](mailto:AdamM@doucetteindustries.com)



**doucette**  
industries, inc

Network User, Doucette Industries 12/5/2014 12:38 PM 92454.dwg

NOTES:

- 1.) DIST #1113-4-3/8, 7/8" OD
- 2.) REF & WATER MANIFOLDS WILL BE 19" LONG
- 3.) 3/8" ACR TUBES (4), WILL BE 24" LONG

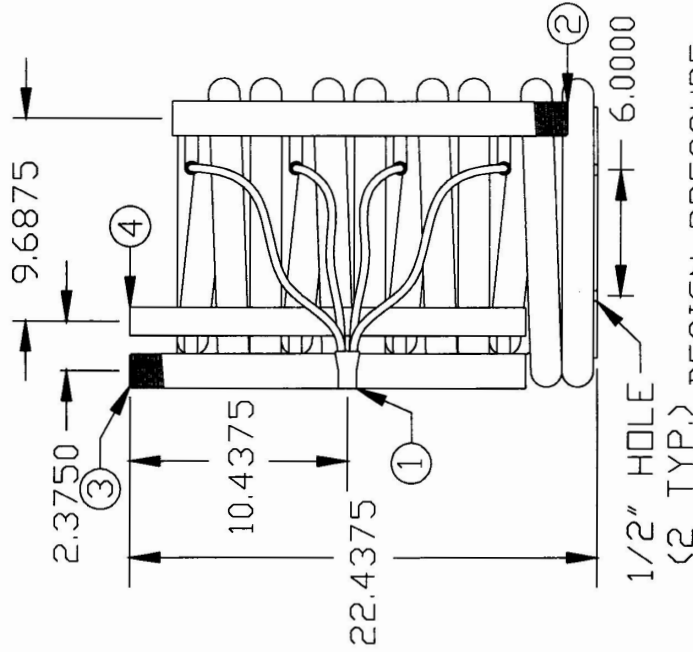
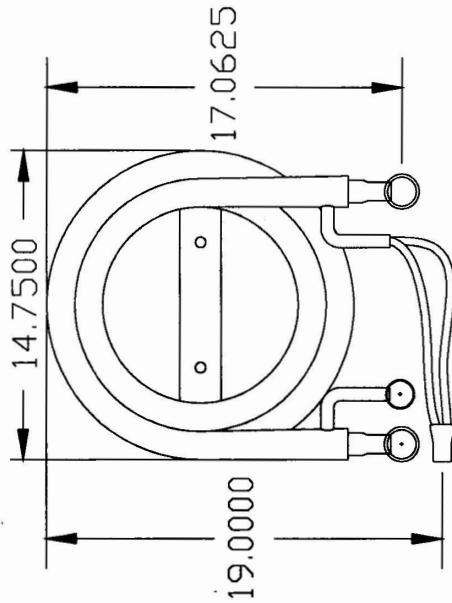

DESIGN PRESSURE:  
SHELL SIDE 450PSIG  
TUBESIDE 350PSIG

TOLERANCES	DOUCETTE INDUSTRIES, INC.	
DECIMAL	.125	SCALE
FRACTIONAL		DRAWN BY: MLB
ANGULAR		APP. BY: RJR
GAUGE		TITLE
		CC 800 T
		DATE
		9/11/00
		DRAWING NUMBER
		92454
		ALL DIMENSIONS INCHES, UNLESS SPECIFIED

CONNECTIONS:

- 1.) REFRIGERANT SUPPLY 7/8" OD SWEAT BRASS
- 2.) WATER SUPPLY 1-1/4" NDM, S/S, 304, NIPPLE
- 3.) WATER RETURN 1-1/4" NDM, S/S, 304, NIPPLE
- 4.) REFRIGERANT RETURN 1-3/8" OD SWEAT COPPER



20 Leigh Drive,  
York, Pennsylvania 17406-8474



Phone: 717-845-8746  
Toll-free: 800-445-7511  
Fax: 717-845-2864



Website: [www.doucetteindustries.com](http://www.doucetteindustries.com)



Commercial/Industrial: [AdamM@doucetteindustries.com](mailto:AdamM@doucetteindustries.com)  
Residential/Light Commercial: [AdamM@doucetteindustries.com](mailto:AdamM@doucetteindustries.com)